

DYNAMIC  
EXAMPLES

# CPS 6000

## Dynamic Monitor System



# PSIDAC

Care is in the Air

# CPS 6000

One room and one system is dynamic and can have various sensors monitored 24/7. And add a slave panel for display of status to staff in working areas, anteroom or corridor so they know before entering the room.

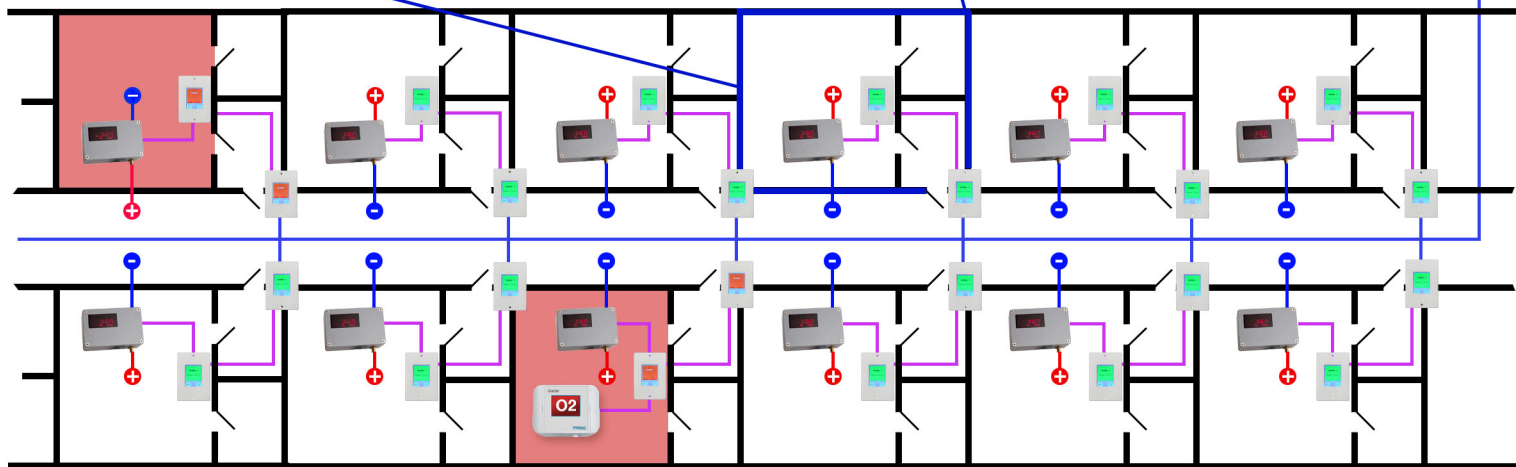
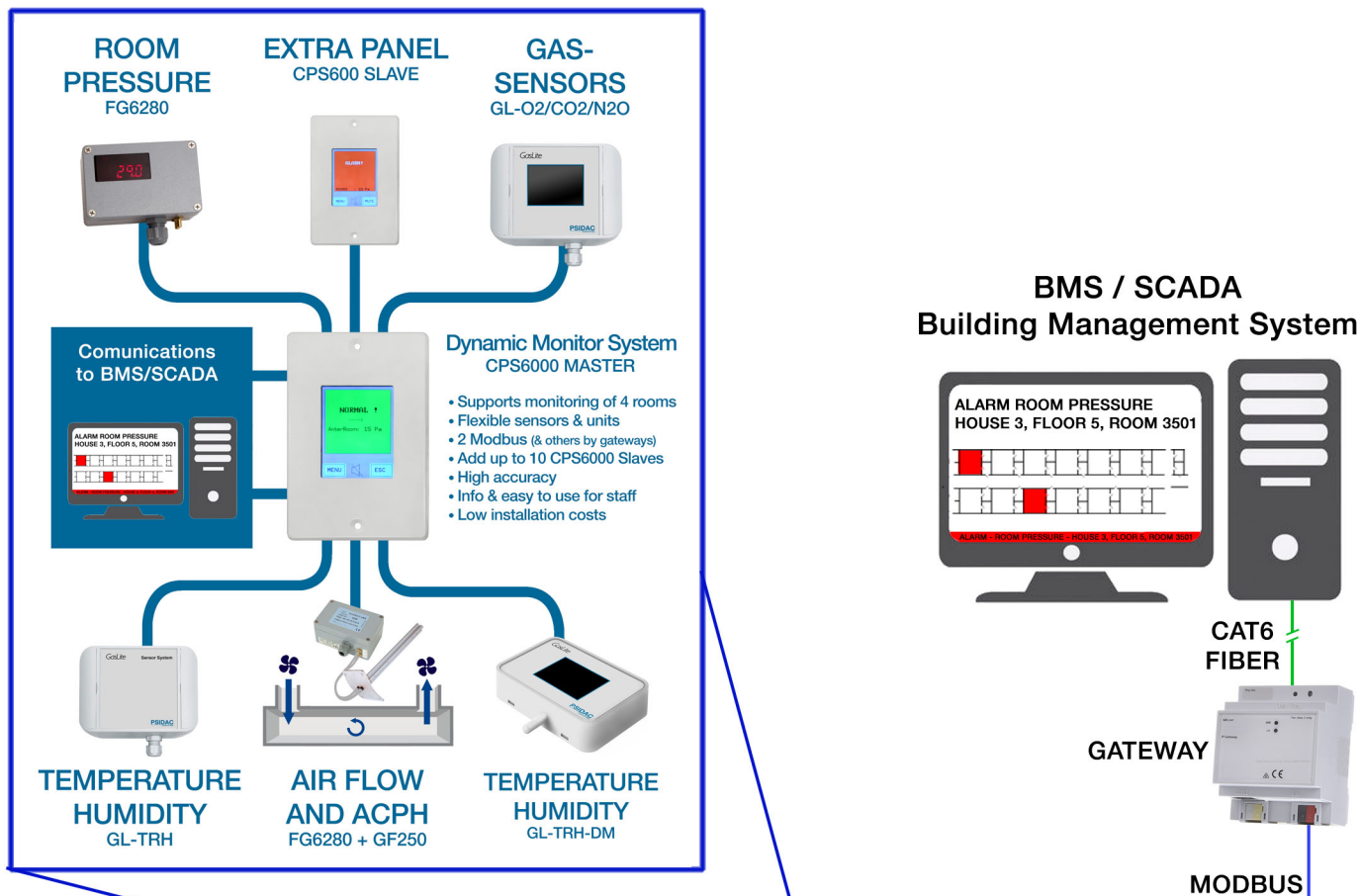

Corridor with positive rooms, airlocks or anterooms. CPS-panel in both corridor and in working area. Rooms can also have gas-sensors (typical O2, CO2, N2O etc), temperature, humidity RH%, airflow measuring to ensure critical air changes per hour (dirty heap filters blocking flow over time), particles in cleanrooms etc. All room systems connected to a modbus that has a gateway in the corridor end, going over to CAT-network or fiber for longer distances. All these rooms/systems reached on one gateway and one IP address, so it can be picked up on a BMS/Scada system in the reception, or another building/town for maintenance, guards/staff to handle alarms. Or the alarm is sent out by SMS or emails depending on type of alarms. Contact us for more info!